

Model: UES-1

Equipment Support

Additional Options:

- 1.
- 2.
- 3.
- 4.

Standard Construction:

18 ga. Galvanized steel shell and baseplate; 10" [254mm] minimum height, 2 x 4 [51 x 102mm] pressure treated wood nailer (std.); raised cant; C-channel bulkheads as required; Fully welded one piece construction, 20 ga galvanized counterflashing. All welds prime painted after fabrication.

AVAILABLE FINISHES:

Durable Polyester Powder (AAMA 2604)

Epoxy Powder

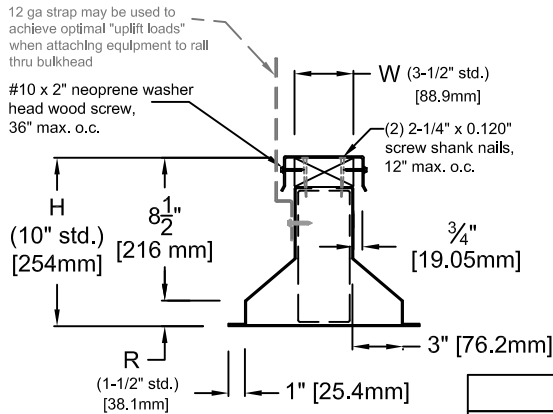
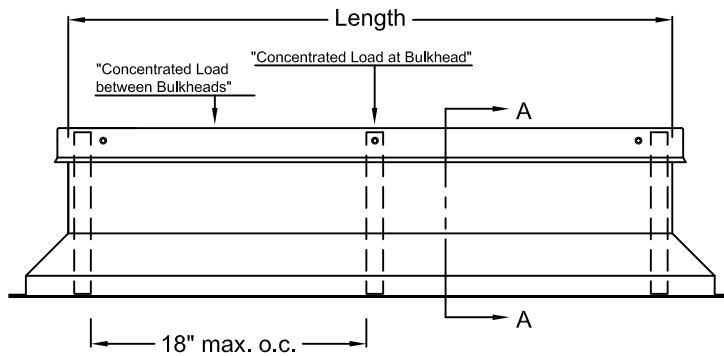

**UES-1
SECTION "A-A"**

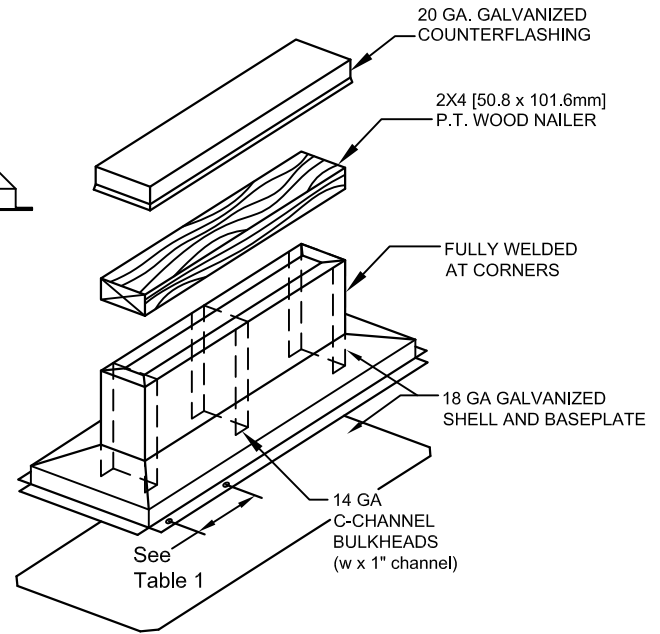

TABLE 1, INSTALLATION SCHEDULE

Specification according to substrate (curb flange attachment to substrate)									
Concrete/CMU (min. 3000 PSI)			Steel (14 ga min.) (Fy=36 ksi)			Wood (G=0.55 density)			
Ø3/8" Expansion Anchor			#14 Sheet Metal Screws			Ø1/4" Lag Screws			
Max. Spacing	Min. Embed.	Min. Edge Distance	Max. Spacing	Min. Embed.	Min. Edge Distance	Max. Spacing	Min. Embed.	Min. Edge Distance	
8" o.c.	3-3/4"	4-1/4"	*8" o.c.	N/A	1"	6" o.c.	2-1/2"	2"	

NOTE: Due to continuing research, United Enertech reserves the right to change specifications without notice.

Qty.	LENGTH	H	W	R	Roof Slope	Tag- Description

DRAWN BY: CLJ	DATE: 8-9-06	REV. NO. 8	REV. DATE: 9-5-17	APPROVED BY: CBY	DWG. NO.: M-5
------------------	-----------------	---------------	----------------------	---------------------	-------------------------