

APPLICATION AND DESIGN

Model **HD-492** is a Round Industrial Air Control Damper with a single skin 3/16" [4.76mm] to 3/8" [9.52mm] thick steel blade. This model consist of a heavy duty flanged frame (10 ga to 3/16" [4.76mm] plate steel) designed for direct attachment to the ductwork or equipment. **HD-492** model is ideal for balancing and/or shut off HVAC applications in the industrial systems with many options to meet your needs.

STANDARD CONSTRUCTION

(see table below for specifics)

- Frame: Carbon steel
- Blades: Steel, reinforced as required
- Axles: Plated steel
- Bearings: Bronze sleeve 200°F [93°C] max
- Finish: Baked Powder Polyester
- Blade Stop: Single Point (not req'd with 1000°F [537°C] blade gasket)
- Seals: None

SIZE LIMITATIONS

Minimum Size: 4" [102mm] Diameter
Maximum Size: 72" [1829mm] Diameter

RATINGS (see page 2)

- Velocity: 6400 fpm
- Pressure: 20 in w.g.- differential pressure
- Temperature: Bronze Brg. -20°F ~ 200°F [-29°C ~ 93°C] (Standard)
- Stainless Brg. 200°F ~ 1,000°F [93°C ~ 537°C] (Optional)

OPTIONS

- Rolled bar stop (1/2" x 1/4" bar thru 17" [13mm x 6.35mm bar thru 432mm], 1/2" x 1/2" bar over 17" [13mm x 13mm bar over 432mm])
- Crosslinked closed cell seal with rolled bar (190°F)[88°C]
- Silica/Woven hi-temp, low leak, 1000° F [538°C] seal
- Bolt Holes
 - one side both sides
- Bearings (see page 3)
Type _____ Upgrade _____
- Hand Quadrant # _____
- Actuator Mounting Plate
- Stainless Steel Construction
 - 304 316 Other _____

AVAILABLE FINISHES:

- Epoxy Powder
- Heresite Coat
- Zinc Rich Gray Primer

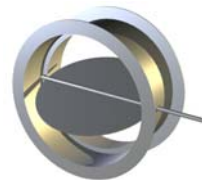
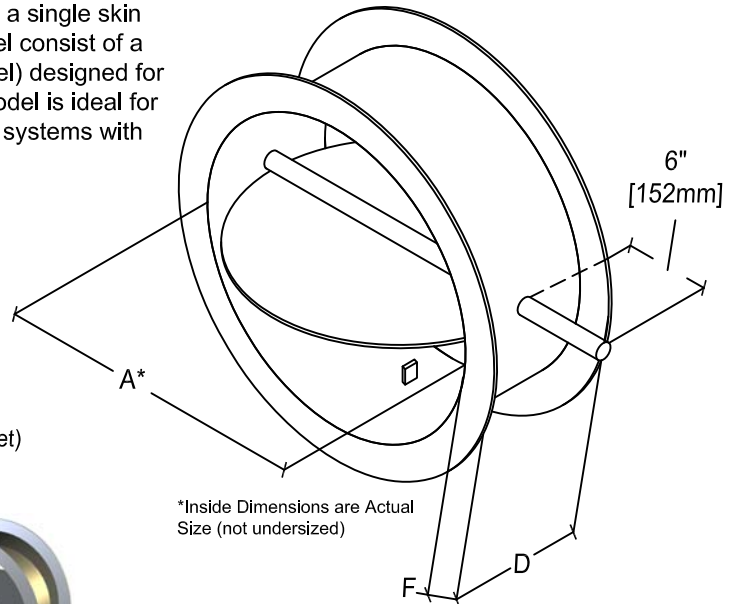

BLADE/FRAME SECTIONS

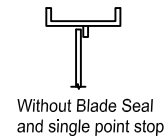

Diameter/ID (A)		Frame		Flange Width F	Axle Diameter	*Blade Thickness
Above	Through	Depth D	Gauge			
3.99" [101]	12" [305]	6" [152]	10	1.25" [32]	0.5" [13]	3/16" (thk) [4.76]
12" [305]	20" [508]	8" [203]	10	1.5" [32]	0.5" [13]	3/16" (thk) [4.76]
20" [508]	24" [610]	8" [203]	10	1.5" [32]	0.75" [19]	3/16" (thk) [4.76]
24" [610]	32" [813]	8" [203]	10	2" [51]	0.75" [19]	1/4" (thk) [6.35]
32" [813]	40" [1016]	8" [203]	3/16" (thk)	2" [51]	0.75" [19]	1/4" (thk) [6.35]
40" [1016]	48" [1219]	8" [203]	3/16" (thk)	2" [51]	1" [25]	1/4" (thk) [6.35]
48" [1219]	54" [1371]	8" [203]	3/16" (thk)	2" [51]	1.5" [38]	3/8" (thk) [9.52]
54" [1371]	60" [1524]	8" [203]	3/16" (thk)	2" [51]	1.5" [38]	3/8" (thk) [9.52]
60" [1524]	72" [1828]	8" [203]	3/16" (thk)	2" [51]	2" [51]	3/8" (thk) [9.52]

*blades reinforced as required.

Job Name:	<input type="checkbox"/> MODEL HD-492		
Location:			
Architect:	DRAWN BY:	DATE:	REV. DATE:
Engineer:	CLJ	12-18-03	10-24-13
Contractor:	REV. NO.	APPROVED BY:	DWG. NO.:
	13	BGT	D-11

MODEL HD-492 PERFORMANCE DATA

Pressure Drop Data

The HVAC system has many factors that effect its internal pressure losses. Dampers in the system is one contributing factor. These dampers have been tested per AMCA Standard 500-D, Fig. 5.3 (ductwork upstream and downstream). There are many influences the ductwork configuration that could effect the performance below such as other objects close to the dampers, elbows or turns near the dampers, internally mounted actuators, etc. This data will assist the designer in the analysis of the system.

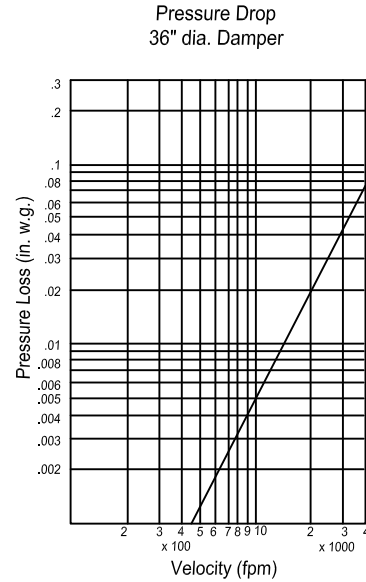
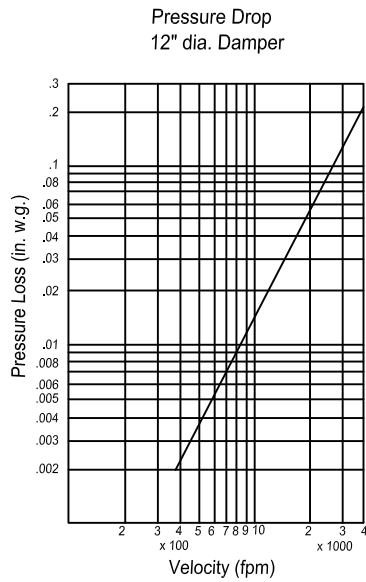

Leakage Data

The damper leakage shown below is per AMCA Standard 500-D. The leakage shown is without seals (standard construction) and with seals, crosslink closed cell or silica/woven. The damper is in the fully closed position.

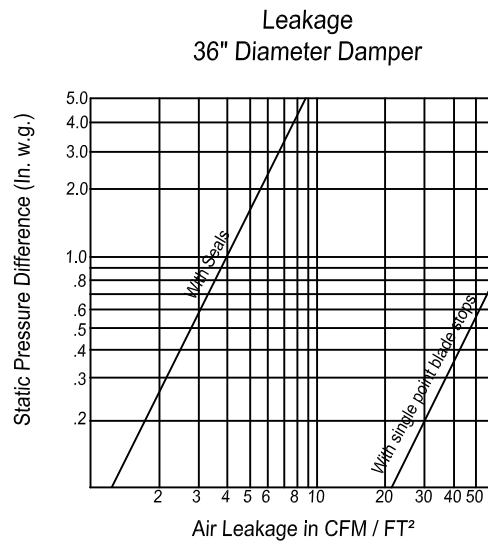
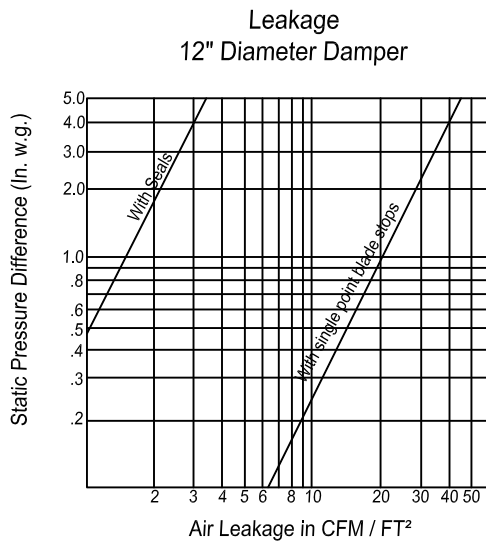

FRAME CONSTRUCTION OPTIONS

Bolt Holes: Standard construction is no bolt holes. Optional: Bolt holes in one flange or both flanges

If bolt holes are required, United Enertech recommends either pattern shown on the drawings below. The patterns shown below "Parallel to Axle" or "Straddle Axle" drawings should be specified when ordering. The table below also gives further details and recommendations on our standard hole patterns. Should a custom hole pattern be required, then it must be approved and sent in at time of order.

Bolt Holes
Parallel to Axle Centerline (P)

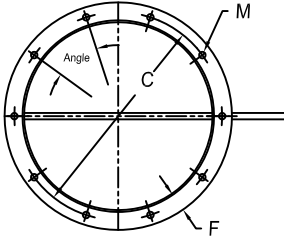

Bolt Holes
Straddle Axle Centerline (S)

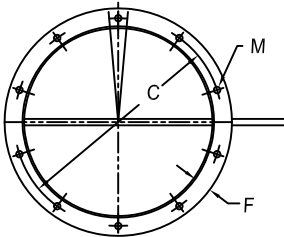

United Enertech Recommended Bolt Hole Pattern
(Bolt Holes Parallel to Axle Centerline)

Diameter/ID (A)		Number of Holes	Mounting Hole Diameter "M"	Bolt Circle Diameter "C"	Degrees Between Holes
Above	Through				
4" [102]	5" [127]	4	3/8" [9.52]	*	90
5" [127]	8" [203]	6	3/8" [9.52]	*	60
8" [203]	11" [279]	6	7/16" [11]	*	60
11" [279]	18" [457]	8	7/16" [11]	*	45
18" [457]	24" [610]	12	7/16" [11]	*	30
24" [610]	36" [914]	16	7/16" [11]	*	22.5
36" [914]	58" [1473]	24	7/16" [11]	*	15
58" [1473]	60" [1524]	32	9/16" [14]	*	11.25
60" [1524]	72" [1828]	36	9/16" [14]	*	10

* Bolt Circle Diameter = Damper Diameter + Flange Height + 1/4" [6.35mm]

Quantity	Max. Temp. (if higher than 250°F)	A Diameter	Bolt Hole Information			
			# of Holes	M Dia.	C Dia.	Placement (P or S)

BEARING AND SHAFT OPTIONS

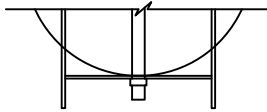

Type 1: Bronze Bushing

Options:

- O-Ring Seal

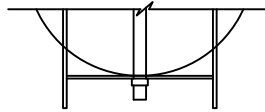

Type 2: Stainless Steel Bushing

Options:

- O-Ring Seal

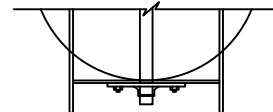

Type 3: Two Hole Pressed Steel Sealed Bearing

Options:

- O-Ring Seal
- Bearing Cover
- Packing Gland, Steel
- Packing Gland, SS
- Stainless Steel Insert

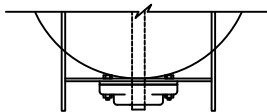

Type 4: Two Hole Cast Iron Bearing

- O-Ring Seal
- Bearing Cover
- Packing Gland, Steel
- Packing Gland, 304 SS
- High Temp (-30°F to 400°F)
- Graphite Ultra High Temp (-132°F to 750°F) Sealed
- Extreme High Temp (-132°F to 1000°F max) Sealed

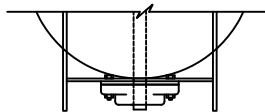

Type 5: Two Hole 304 Stainless Steel Bearing

Options:

- Hi Temp, 400° F
- Hi Temp, graphite 750° F
- Hi Temp, graphite 1000° F
- Bearing Cover
- Packing Gland, Steel
- Packing Gland, 304 SS

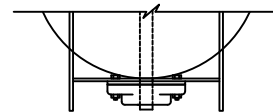

Type 6: Two Hole Thermo Plastic Bearing

Options:

- Bearing Cover
- Packing Gland, Steel
- Packing Gland, 304 SS

ACTUATOR OPTIONS

Model **HD-492** has available many operators shown below that can be factory mounted by United Enertech. Consult factory for other operators not shown.

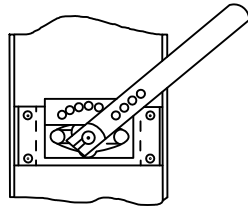

Hand Quadrant #2

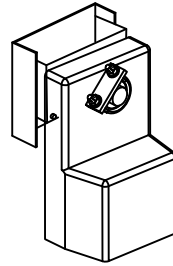

Direct Drive Mounted
Electric Actuators

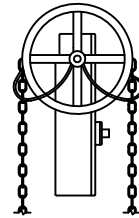

Pull Chain and
Worm Gear

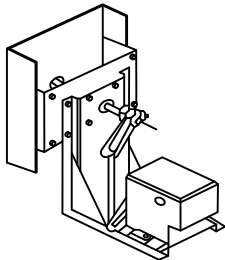

Foot Mounted Actuators
Such as Honeywell,
Siebe/Barber Coleman

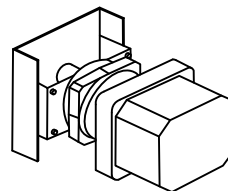

RCS Surepowr TM

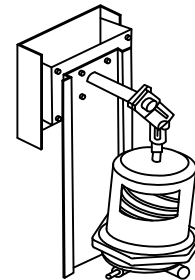

Pneumatic Diaphragm

SPECIFICATIONS:

Industrial Round Dampers meeting the following specifications shall be furnished and installed where shown on drawings and described in the schedule. The damper frame shall consist of heavy gauge steel (10 ga - 3/16" plate) rolled with a 1-1/4" minimum depth flange/web. The damper blade shall be of a single thickness, heavy gauge steel (3/16" plate < 24"D, 24"-48"D = 1/4" plate, 3/8" thick plate > 54"). The axle shall be a continuous length of 1/2" dia. up to 20", 3/4" dia. up to 40", 1" dia. up to 48", 1.5" dia up to 60", and 2" dia over 60". Bearings shall be of the bronze sleeve type to minimize wear. Also submitted with submittal package is the dampers performance data such as pressure drop, leakage, and temperature ratings. The damper shall be suitable for velocities up to 6400 fpm at a pressure differential of 20" wg. Damper shall be United Enertech Model HD-492 or equivalent.

ADDITIONAL INFORMATION THAT MAY BE ADDED TO SPECIFICATIONS:

Damper shall be factory supplied with Blade Seals for low leakage. Blade Seals shall be Crosslinked Closed Cell (190°F maximum temperature) or Silica/woven Hi-temp (Up to 1000°F) {Specifier to choose one}. Damper leakage for a 36" diameter damper to be less than 4 cfm/ft² at 1" w.g. and less than 8 cfm/ft² at 4" w.g. shall be submitted for approval on manufacturer's submittal data. Bearing type upgrades may be specified. See United Enertech's Bearing Chart for variations.



Chattanooga, TN 37407