

**Model: FCA-2**

Fan Curb Adapter

Additional Options:

- 1.
- 2.
- 3.
- 4.

**Standard Construction:**

18 ga. Galvanized steel construction. Insulated, internal angle reinforcing with welded corners.

**AVAILABLE FINISHES:**

Durable Polyester Powder (AAMA 2604)

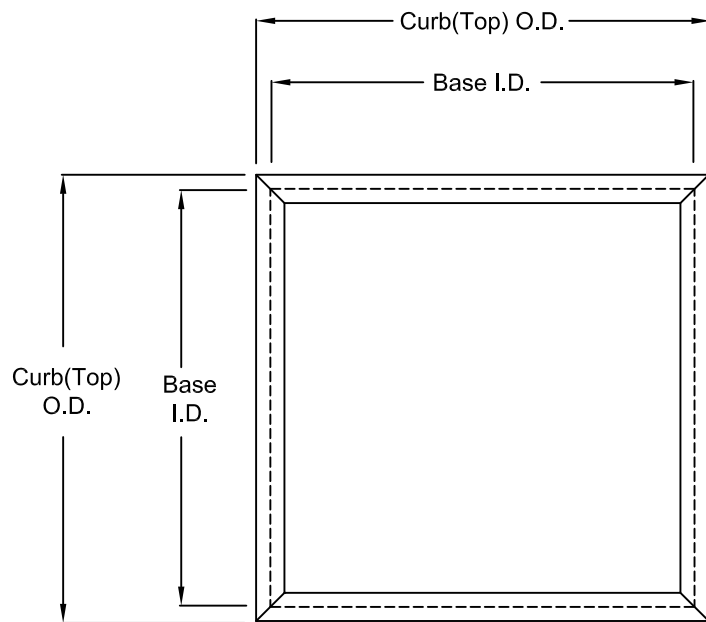

PLAN

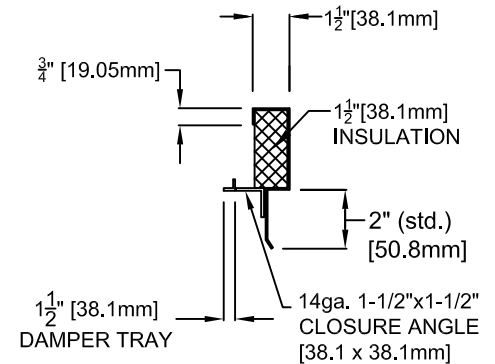
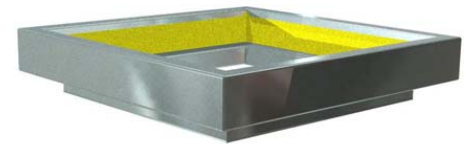

FCA-2 SECTION

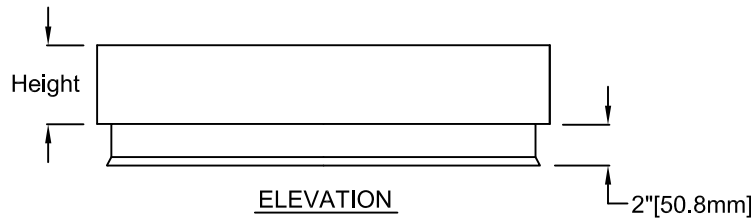

ELEVATION

Due to continuing research, United Enertech reserves the right to change specifications without notice.

Qty.	Base I.D.	Curb(Top) O.D.	Height	Tag- Description

DRAWN BY: CLJ	DATE: 8-28-06	REV. NO. 9	REV. DATE: 9-21-16	APPROVED BY: CJ	DWG. NO.: <b>M-11</b>
------------------	------------------	---------------	-----------------------	--------------------	--------------------------