

Application/Design:

The Model i-4S was developed for air balancing at the mid/duct above inaccessible ceilings with adjustments accomplished by a hand-held power pack.

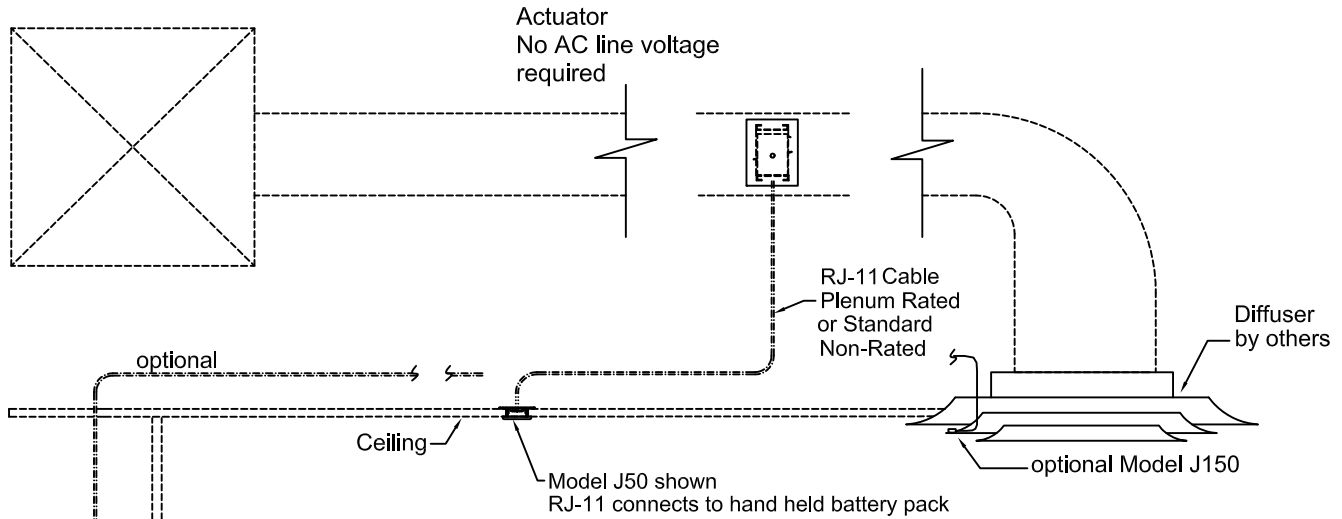

Model i-4S (Rectangular)

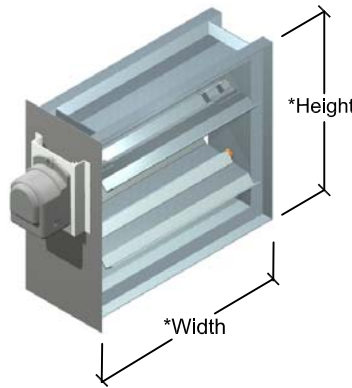

*Undersized 1/4"

Max Size: 4 sq. ft. 48"w x 12"h
12"w x 48"h
24"w x 24"h

Min. Size: 6"w x 6"h

Features:

Frame: 18 ga galvanized, 5" deep

Blade: 16 ga galvanized

Bearings: Bronze Oilite

Axles: 1/2" dia. zinc plated steel with thrust bearing

Side Plate: 6-1/4" x (ht. +1") x 18 ga galv. steel
(Note: actuator mounting plate is 6063-t5 alum.)

RECOMMENDED SPECIFICATIONS

- A. The remote control system shall provide means of balancing airflow in ductwork above inaccessible ceilings
- B. In these areas, the contractor shall furnish and install Model i-4S (inline) in the branch duct. The drive actuator shall be DC voltage.
- C. The contractor shall furnish and install remote plate options of Model J50, J100, or J150 terminal point. Color shall be white unless otherwise specified. (see dwg. D-4)
- D. The contractor shall connect RJ-11 Plenum Rated or Standard Non-Rated cable from the damper to the female outlet. Plenum Rated cables are capable of lengths up to 1000 feet.
- E. The balancing shall be achieved with a hand held power pack, utilizing an RJ-11 connector. Contractor shall turn over the hand held power packs to the owner after balancing is complete.
- F. The *Power / Balance System™* shall be manufactured by United Enertech Corporation.

WARRANTY:

To avoid any warranty issues, all components, including those from the wall jack to actuator, must be supplied by United Enertech.

Due to continuing research, United Enertech reserves the right to change specifications without notice.

U.S. Pat. No. 8,038,075
Air Damper balancing system and method

Job Name:	DRAWN BY:	DATE:	REV. DATE:
Location:	CLJ	9-11-19	10-25-19
Architect:	REV. NO.	DWG. NO.:	
Engineer:	2	E-2a	
Contractor:			