

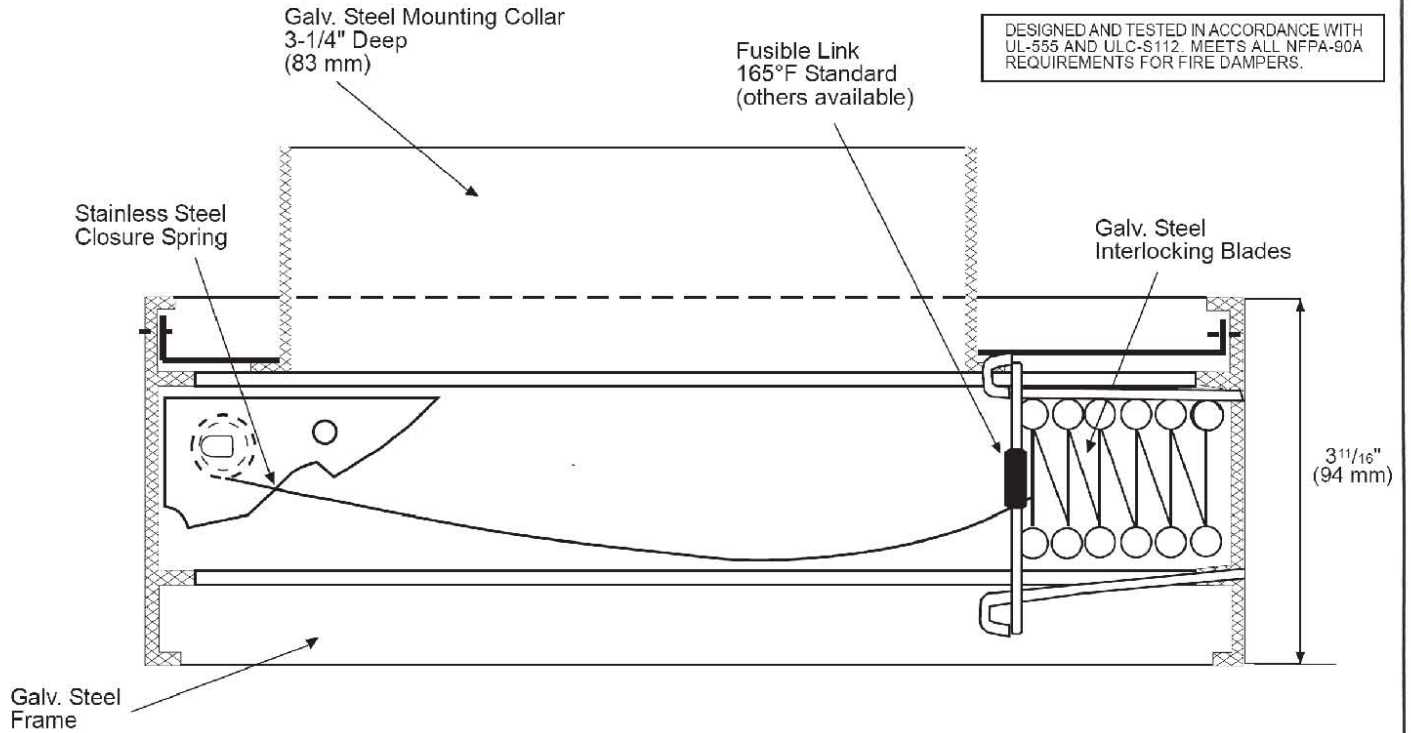

**MODEL FD-B-GC GARBAGE CHUTE FIRE DAMPER  
 STATIC FIRE DAMPER  
 FOR HORIZONTAL MOUNTING**



DESIGNED AND TESTED IN ACCORDANCE WITH UL-555 AND ULC-S112. MEETS ALL NFPA-90A REQUIREMENTS FOR FIRE DAMPERS.



**NOTE:**

This is a specially designed, spring loaded horizontal fire damper- 1<sup>1/2</sup> hr. rated complete with over-sized housing & round collar for garbage chute applications. The damper has 100% free area.

**OPTIONS:**

- Electro thermal links
- Fusible Link 212°F

"These Dampers are UL/ULC Approved For Use in Static Systems Where The Fan Shuts Down in the Event of a Fire."

**STANDARD SIZES: (Others on request)**

Diameter	Overall Size
20" (508mm)	26"w x 27"h
24" (610mm)	30"w x 32"h

Job Name:	<input type="checkbox"/> <b>MODEL FD-B-GC</b>		
Location:			
Architect:			
Engineer:	DRAWN BY: MAB	DATE: 11-06-07	REV. DATE: 4-11-08
Contractor:	REV. NO. 5	APPROVED BY: BGT	DWG. NO.: <b>A-26</b>